

WARNING

PLEASE READ THE ENTIRE CONTENTS OF THIS MANUAL PRIOR TO INSTALLATION AND OPERATION. BY PROCEEDING YOU AGREE THAT YOU FULLY UNDERSTAND AND COMPREHEND THE FULL CONTENTS OF THIS MANUAL. FORWARD THIS MANUAL TO ALL OPERATORS. FAILURE TO OPERATE THIS EQUIPMENT AS DIRECTED MAY CAUSE INJURY OR DEATH.

Revision B — May 2017
Part Number 5900391

INSTALLATION AND OPERATION MANUAL

ELITE™ AIR COMPRESSOR - 80-GALLON VERTICAL TANK

MODEL:
TS-580V-601



READ FIRST



Do not operate this machine until you read and understand all the dangers, warnings and cautions in this manual.

Keep this operation manual near the machine at all times. Make sure that ALL USERS read this manual.

SHIPPING DAMAGE CLAIMS

When this equipment is shipped, title passes to the purchaser upon receipt from the carrier. Consequently, claims for the material damaged in shipment must be made by the purchaser against the transportation company at the time shipment is received.

BE SAFE

Your new BendPak air compressor was designed and built with safety in mind. However, your overall safety can be increased by proper training and thoughtful operation on the part of the operator. **DO NOT** operate or repair this equipment without reading this manual and the important safety instructions shown inside.



1645 Lemonwood Dr.
Santa Paula, CA. 93060, USA
Toll Free 1-800-253-2363
Tel: 1-805-933-9970
Fax: 1-805-933-9160
www.bendpak.com

DESCRIPTION

Air compressor units are intended to provide compressed air to power pneumatic tools, operate spray guns and supply air for pneumatic valves and actuators. The pumps supplied with these units have oil lubricated bearings. A small amount of oil carryover is present in the compressed air stream. Applications requiring air free of oil vapor should have the appropriate filter installed. The air compressor units are to be mounted on a level floor per the instructions provided. Any other use of these units will void the warranty and the manufacturer will not be responsible for problems or damages resulting from such misuse.

SAFETY GUIDELINES

This manual contains information that is very important to know and understand. This information is provided for SAFETY and to PREVENT EQUIPMENT PROBLEMS. To help recognize this information, observe the following symbols.



Watch for this symbol. It Means: Immediate hazards which will result in severe personal injury or death.



Watch for this symbol. It Means: Hazards or unsafe practices which could result in severe personal injury or death.



Watch for this symbol. It Means: Hazards or unsafe practices which may result in minor personal injury or product or property damage.

INTRODUCTION

1. Carefully remove the crating and packing materials. **CAUTION!** Be careful when cutting steel banding material as items may become loose and fall causing personal harm or injury.

2. Check the voltage, phase and proper amperage requirements for the motor shown on the motor plate. Wiring should be performed by a certified electrician only.

3. Confirm voltage before connecting power to your machine or serious damage to the motor/electronics will result.



BREATHABLE AIR WARNING

This compressor/pump is NOT equipped and should NOT be used "as is" to supply breathing quality air. For any application of air for human consumption, you must fit the air compressor/pump with suitable in-line safety and alarm equipment. This additional equipment is necessary to properly filter and purify the air to meet minimal specifications for Grade D breathing as described in Compressed Gas Association Commodity Specification G 7.1 - 1966, OSHA 29 CFR 1910. 134, and/or Canadian Standards Associations (CSA).

DISCLAIMER OF WARRANTIES

In the event the compressor is used for the purpose of breathing air application and proper in-line safety and alarm equipment is not simultaneously used, existing warranties are void, and the company disclaims any liability whatsoever for any loss, personal injury or damage.

UNPACKING

After unpacking the unit, inspect carefully for any damage that may have occurred during transit. Make sure to tighten fittings, bolts, etc., before putting unit into service.



Do not operate unit if damaged during shipping, handling or use. Damage may result in bursting and cause injury or property damage.



Failure to follow danger, warning, and caution instructions may lead to serious personal injury or death to operator or bystander or damage to property. Do not operate this machine until you read and understand all the dangers, warnings and cautions in this manual.

For additional copies
or further information, contact:

BendPak Inc. / Ranger Products
1645 Lemonwood Dr.,
Santa Paula, CA. 93060
1-805-933-9970
www.bendpak.com

GENERAL SAFETY

Since the air compressor and other components (material pump, spray guns, filters, lubricators, hoses, etc.) may be under high pressure and be subject to explosions, the following safety precautions must be observed at all times:

1. **READ AND UNDERSTAND** all safety warning procedures before installation and operation.



2. **KEEP HANDS AND FEET CLEAR.** Remove hands and feet from any moving parts.

3. **KEEP WORK AREA CLEAN.** Cluttered work areas invite injuries.

4. Consider work area environment. Do not expose equipment to rain. **DO NOT** use in damp or wet locations. Keep area well lighted.

5. **ONLY TRAINED OPERATORS** should operate this equipment. All non-trained personnel should be kept away from work area. Never let non-trained personnel come in contact with, or operate machine.

6. **USE MACHINE CORRECTLY.** Use machine in the proper manner. Never use adapters other than what is approved by the manufacturer.

7. **DO NOT** override or disable safety valves and/or devices.

8. **NEVER** operate compressor without a belt guard. This unit can start automatically without warning. Personal injury or property damage could occur from contact with moving parts.



9. **GUARD AGAINST ELECTRIC SHOCK.** This equipment must be grounded while in use to protect the operator from electric shock. Never connect the green power cord wire to a live terminal. This is for ground only. Follow all local electrical and safety codes as well as the United States National Electrical Codes (NEC) and Occupational Safety and Health Act (OSHA).



10. **DANGER!** The motor on this machine contains high voltage. Disconnect power at the receptacle before performing any electrical repairs. Secure plug so that it cannot be accidentally plugged in during service.



11. **WARNING! RISK OF EXPLOSION.** This equipment has internal arcing or sparking parts which should not be exposed to flammable vapors. This machine should not be located in a recessed area or below floor level.



12. Tanks rust from moisture build-up, which weakens the tank. Make sure to drain tank regularly and inspect periodically for unsafe conditions such as rust formation and corrosion.

13. **STAY ALERT.** Watch what you are doing. Use common sense. Be aware.

14. **DRESS PROPERLY.** Non-skid steel-toe footwear is recommended when operating machine.

15. **CHECK FOR DAMAGED PARTS.** Check for condition of all moving parts, breakage of parts or any condition that may affect the machines operation. Do not use if any component is broken or damaged.



16. An ASME code safety relief valve with a setting no higher than the Maximum Allowable Working Pressure (MAWP) of the tank **MUST** remain installed on this compressor to protect the pressurized components from bursting. Maximum pressure is 175 psi. Do not operate with pressure switch or pilot valves set higher than 175 psi. Never attempt to adjust ASME safety valve. Keep safety valve free from paint and other accumulations.

17. **NEVER** remove safety related components or device from the machine. Do not use if safety related components are damaged or missing.

18. Before each use, inspect compressed air system and electrical components for signs of damage, deterioration, weakness or leakage. Repair or replace defective items before using.

19. Check all fasteners at frequent intervals for proper tightness.

20. Compressor parts may be hot even if the unit is stopped. Keep fingers away from a running compressor; fast moving and hot parts will cause injury and/or burns.



21. If the equipment should start to vibrate abnormally, **STOP** the engine/motor and check immediately for the cause. Vibration is generally an indication of trouble.

22. To reduce fire hazard, keep engine/motor exterior free of oil, solvent, or excessive grease.



22. Never attempt to repair or modify a tank! Welding, drilling or any other modification will weaken the tank resulting in damage from rupture or explosion. Always replace worn, cracked or damaged tanks. Drain liquid from tank daily.

SPRAYING PRECAUTIONS

1. Fast moving air will stir up dust and debris which may be harmful. Release air slowly when draining moisture or depressurizing the compressor system.
2. Do not spray flammable materials in vicinity of open flame or near ignition sources including the compressor unit. Do not smoke when spraying paint, insecticides, or other flammable substances.
3. Use a face mask/respirator when spraying and spray in a well ventilated area to prevent health and fire hazards.
4. Do not direct paint or other sprayed material at the compressor. Locate compressor as far away from the spraying area as possible to minimize overspray accumulation on the compressor.
5. When spraying or cleaning with solvents or toxic chemicals, follow the instructions provided by the chemical manufacturer.

INSTALLATION

! WARNING

Disconnect, tag and lock out power source then release all pressure from the system before attempting to install, service, relocate or perform any maintenance.

! DANGER

Do not lift or move unit without appropriately rated equipment. Be sure the unit is securely attached to lifting device used.

Do not lift unit by holding onto tubes or coolers.

Never use the wood shipping skids for mounting the compressor.

Install and operate unit at least 24" from any obstructions in a clean, well ventilated area. The surrounding air temperature should not exceed 100* F. This will ensure an unobstructed flow of air to cool compressor and allow adequate space for maintenance.

! CAUTION

Do not locate the compressor air inlet near steam, paint spray, sandblast areas or any other source of contamination.

NOTE: If compressor operates in a hot, moist environment, supply compressor pump with clean, dry outside air. Supply air should be piped in from external sources.

TANK MOUNTING

The tank should be bolted into a flat, even, concrete floor or on a separate concrete foundation. Anti-vibration pads should be used between the tank leg and the floor. When using anti-vibration pads, do not draw bolts tight. Allow the pads to absorb vibrations. When isolators are used, a flexible hose or coupling should be installed between the tank and service piping.

! DANGER

Failure to properly install the tank can lead to cracks at the welded joints and possible bursting.

The compressor must be properly mounted to a concrete floor as illustrated. Bolting holes are provided in the base feet. Mount the air compressor on a solid, level foundation. Support air compressor weight evenly on all four feet. Solid shims may be used if necessary.

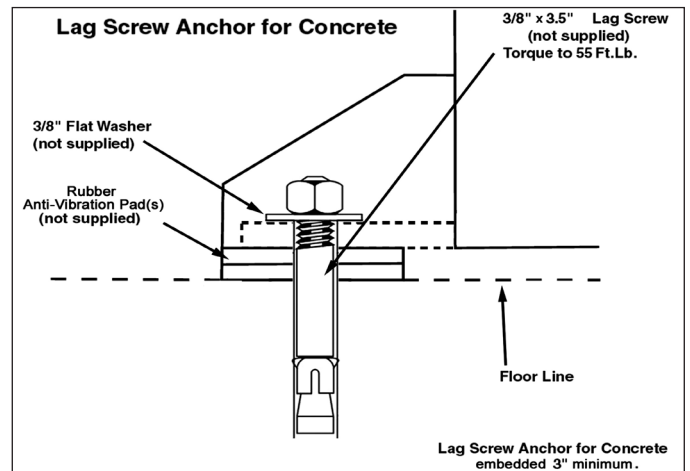

PIPING

! WARNING

Never use plastic (PVC) pipe for compressed air. Serious injury or death could result.

Any tube, pipe or hose connected to the unit must be able to withstand the temperature generated and retain the pressure. All pressurized components of the air system, tube, pipe or hose must have a pressure rating higher than or equal to 200 psi or bursting could result and injury occur.

Connect piping system to tank using the same size fitting as the discharge port.

Pipe thread lubricant must be used on all male pipe threads, and all joints are to be made up tight, since small leaks in the piping system are the largest single cause of high operating costs. All piping should be sloped to an accessible drain point and all outlets should be taken from the top of the main distribution air line so that moisture cannot enter the outlet.

WIRING



All wiring and electrical connections must be performed by a qualified electrician. Installations must be in accordance with local and national codes.

Overheating, short circuiting and fire damage will result from inadequate wiring. Wiring must be installed in accordance with National Electrical Code and local codes and standards that have been set up covering electrical apparatus and wiring.

Be certain that adequate wire sizes are used, and that:

1. Service is of adequate ampere rating.
2. The supply line has the same electrical characteristics (voltage, cycles and phase) as the motor.
3. The line wire is the proper size and that no other equipment is operated from the same line. The chart below gives minimum recommended wire sizes for compressor installations.

MINIMUM PIPE SIZE FOR COMPRESSED AIR LINE				
CFM	Length Of Piping System			
	25'	50'	100'	250'
10	1/2"	1/2"	3/4"	3/4"
20	3/4	3/4	3/4	1
40	3/4	1	1	1
60	3/4	1	1	1
100	1	1	1	1 1/4

INSTALLING A SHUT-OFF VALVE

A shut-off valve should be installed on the discharge port of the tank to control the air flow out of the tank. The valve should be located between the tank and the piping system.



Never install a shut-off valve between the compressor pump and the tank. Personal injury and/or equipment damage may occur. Never use reducer in discharge piping.

When creating a permanently installed system to distribute compressed air, find the total length of the system and select pipe size from the chart. Bury underground lines below the frost line and avoid pockets where condensation can gather and freeze.

Apply air pressure to the piping installation and make sure all joints are free from leaks BEFORE underground lines are covered. Before putting the compressor into service, find and repair all leaks in the piping, fittings and connections.

MINIMUM WIRE SIZE USE 75°C COPPER WIRE				
HP	Amps	Single Phase	Three Phase	
		230V	208/230V	460/575V
SPL	up to 22.0	10 AWG		
5.0		8 AWG	12 AWG	14 AWG
7.5		8 AWG	10 AWG	12 AWG
10.0		N/A	8 AWG	12 AWG
15.0		N/A	6 AWG	10 AWG
25.0		N/A	3 AWG	8 AWG



FOR TECHNICAL SUPPORT, PLEASE CALL:
1-(800) 253-2363 Ext. 196

TO ORDER PARTS, PLEASE CALL:
1-(800) 253-2363 Ext. 191

V-MAX SERIES DESCRIPTION OF PARTS

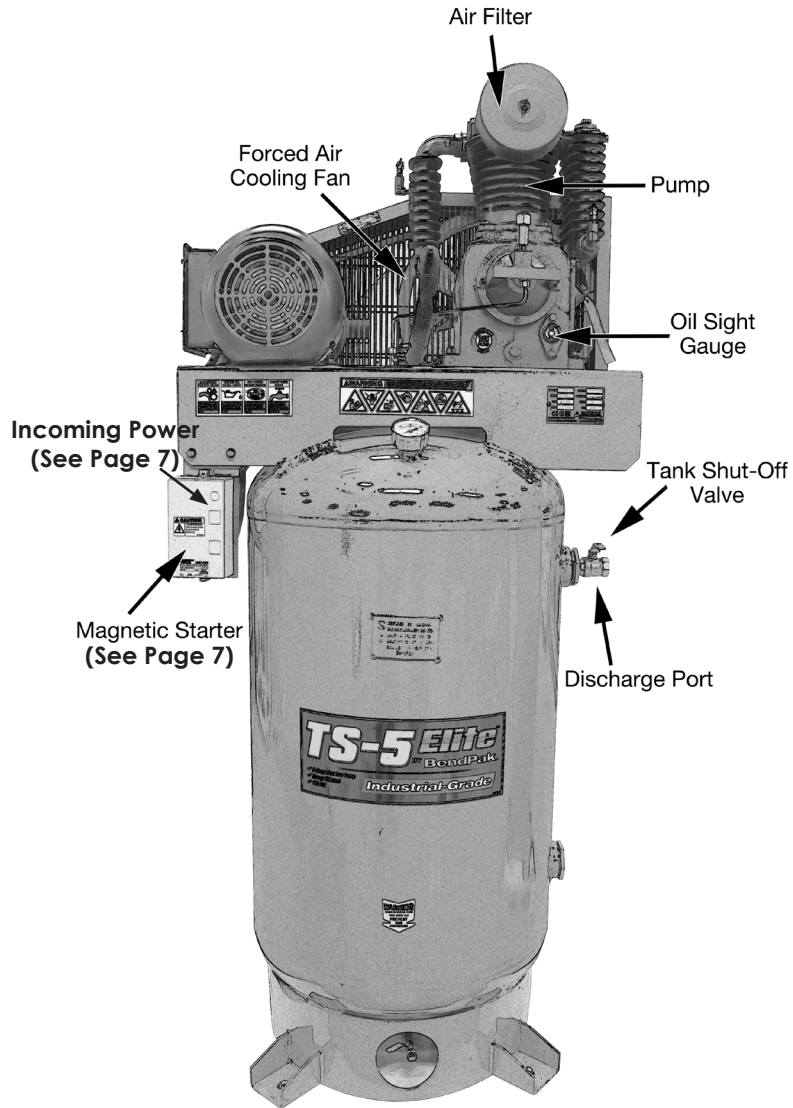

**ON/OFF SWITCH
SIDE VIEW**

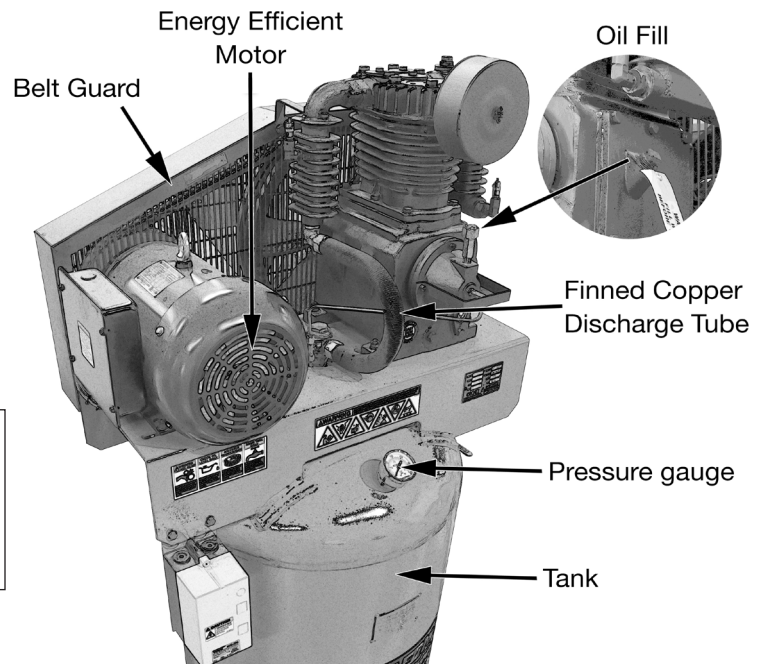
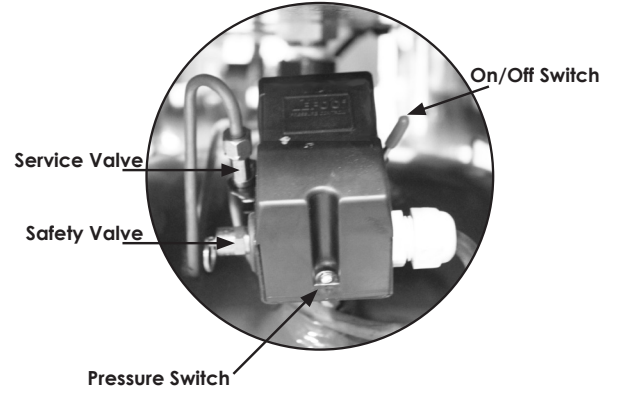

NOTE:
THIS UNIT CONTAINS NO OIL WHEN SHIPPED.
FILL WITH OIL BEFORE OPERATING COMPRESSOR.
USE ONLY THIS RECOMMENDED OIL:
ISO100, NON-DETERGENT, COMPRESSOR OIL.

Recommended wire sizes may be larger than the minimum set up by local ordinances. If so, the larger size wire should be used to prevent excessive line voltage drop. The additional wire cost is very small compared with the cost of repairing or replacing a motor electrically “starved” by the use of supply wires which are too small.

! DANGER

Improperly grounded electrical components are shock hazards. Make sure all the components are properly grounded to prevent death or serious injury.



! WARNING

This product must be grounded. Grounding reduces the risk of electrical shock by providing an escape wire for the electric current if short circuit occurs. This product must be installed and operated with a power cord or cable that has a grounding wire.

GUARDING

The belt guard provided must be installed before operating the unit. All moving parts must be guarded. All electrical covers must be installed before turning on the power.

DIRECTION OF ROTATION

To change to the alternate voltage on **three phase motors** with 230/460 ratings. The voltage and amperage ratings are listed on the motor nameplate:

1. Rewire motor per data plate on motor or instruction sheet.
2. Check electric rating of magnetic starter and replace thermal overload elements as required.

! CAUTION

Improper rotation will result in reduced unit life. The direction of rotation must be counterclockwise while facing the flywheel side of the pump. The motor nameplate will show wiring information for counterclockwise rotation. The proper direction is very important. The direction of rotation on 3 phase motors can be reversed by interchanging any two motor-line leads.

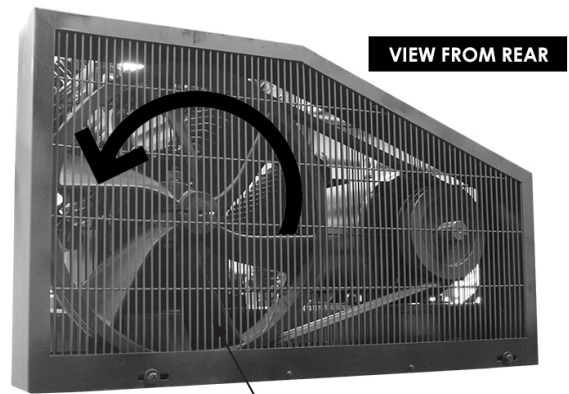

Pump Fan
Counter Clockwise Rotation

See Magnetic Starter on page 6

WIRING DIAGRAMS

Single phase
208-230 VAC, 50/60 Hz

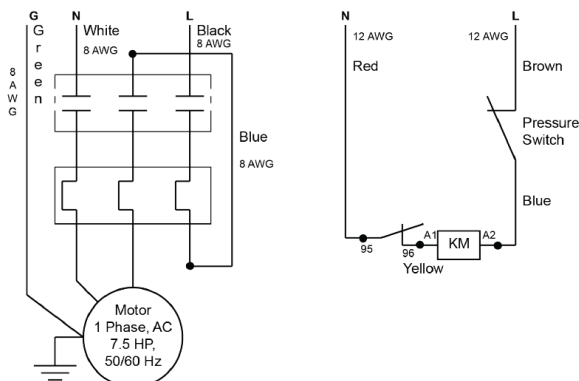

SINGLE PHASE

NON-REVERSING STARTER

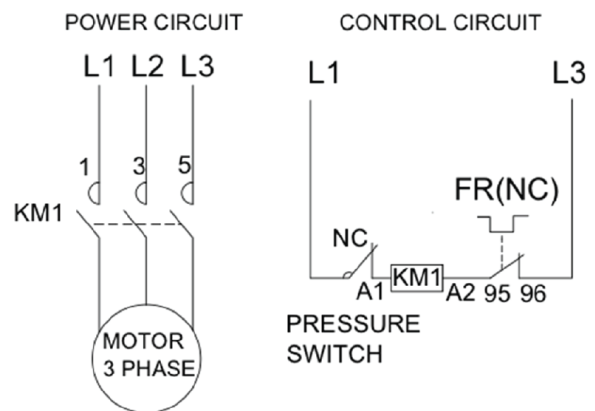

THREE PHASE

LUBRICATION



THIS UNIT CONTAINS NO OIL WHEN SHIPPED. FILL WITH OIL BEFORE OPERATING COMPRESSOR.

Fill to the center of the sight gauge as shown in the image below.

Some residual oil may still be in the pump, leaving a thin coat on the sight glass. However, this is not enough oil to operate the unit. Fill pump with single-viscosity, ISO100, non-detergent, compressor oil.

AFTER the first 300 hours, add oil only through the oil fill plug. Pouring oil into any other orifice will cause oil to leak and spray out during operation. Fill to the center of the sight gauge, as shown in the picture below.

IMPORTANT: Change oil after first 8 hours of operation. Using any other type of oil may shorten pump life and damage components.

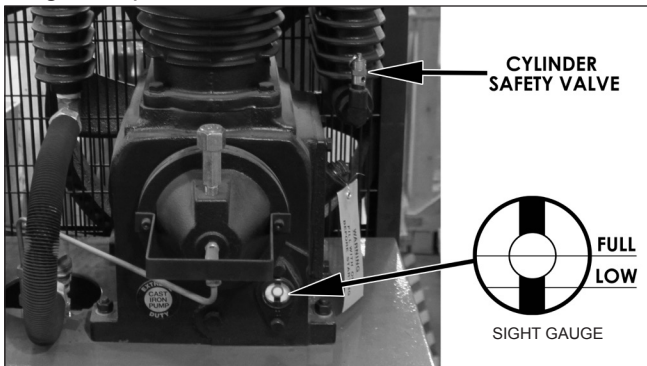

PRESSURE SWITCH, START - STOP



NOTE: This compressor has a maximum pressure of 175 psi. Do not alter pressure settings on control components above this limit.



The compressor unit starts and stops based on preset pressure switch settings.

ON/AUTO-OFF SWITCH LEVER

Turn this switch ON to provide automatic power to the pressure switch and OFF to remove power.

PRESSURE SWITCH

The pressure switch automatically starts the motor when the air tank pressure drops below the factory set "cut-in" pressure of 140 psi. It stops the motor when the air tank pressure reaches the factory set "cutout" pressure of 175 psi.

DO NOT ADJUST THESE SETTINGS. DOING SO WILL DAMAGE MOTOR AND VOID WARRANTY.

AIR TANK SAFETY VALVE

If the pressure switch does not shut off the air compressor at its cut-out pressure setting, the safety valve will protect against high pressure by "popping off" at its factory set pressure (slightly higher than the pressure switch cut-out setting).

AIR TANK PRESSURE GAUGE

The air tank pressure gauge indicates the reserve air pressure in the air tank.



The ASME safety valve should also be checked daily. Pull ring on safety valve and allow the ring to snap back to normal position. This valve automatically releases air if the tank pressure exceeds the preset maximum.

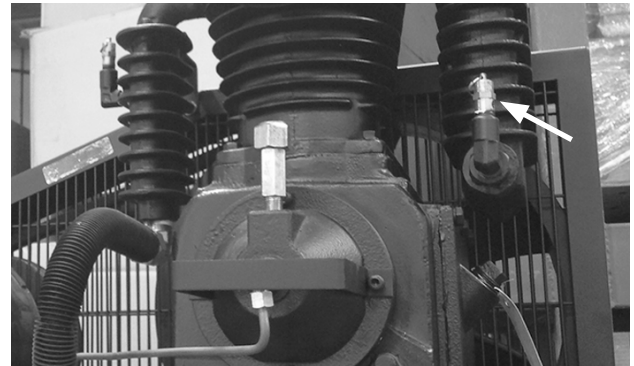

Do not attempt to tamper or disable the ASME safety valve.



If air leaks after the ring has been released, or the valve is stuck and cannot be actuated by the ring, the ASME safety valve must be replaced. If the safety valve does not work properly, over-pressurization may occur causing air tank rupture or explosion. Occasionally pull the ring on the safety valve to make sure that the safety valve operates freely. If the valve is stuck or does not operate smoothly, it must be replaced with a valve having the same pressure rating.



BREAK-IN PROCEDURES

This procedure is required before the air compressor is put into service, before the hose is installed, the check valve is replaced, or a complete compressor pump is replaced.

Serious damage may result if the following break-in instructions are not closely followed.

Procedure:

1. Make sure the pressure switch lever is in the "OFF" position. (See image below).

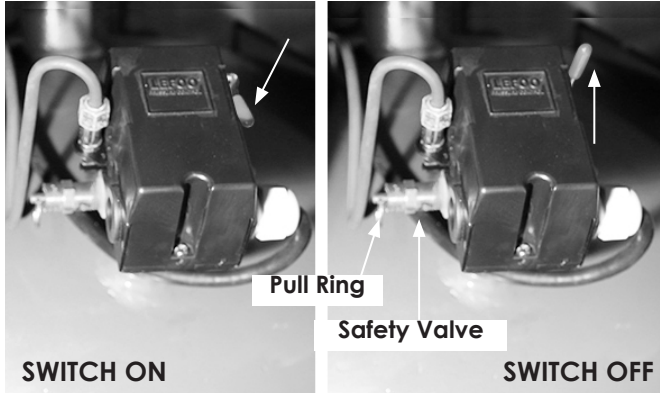

2. Check air compressor wiring. Make sure wires are secure at all terminal connections.

3. Close the tank shut-off valve then open the drain valve fully to permit air to escape and prevent air pressure buildup in the air tank during the break-in period.

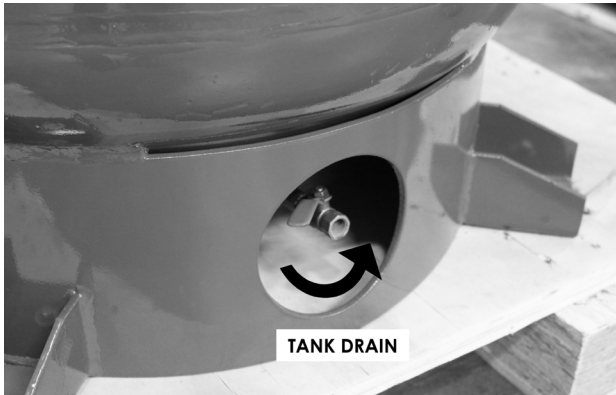

4. Move the pressure switch lever to "ON/AUTO". The compressor will start.

5. Run the air compressor for 30 minutes. Make sure the drain valve is open and there is minimal air pressure build-up in tank.

6. After 30 minutes move the pressure switch lever to the OFF position, check oil and add if necessary.

7. Close the air tank drain valve.

8. Move the pressure switch lever to "ON/AUTO". The air receiver will fill to cutout pressure and the motor will stop. Your air compressor is now ready for use.

OPERATING PROCEDURES

Daily Start-Up Checklist

1. Check oil and add if necessary. Do not change oil while compressor is in operation.

2. Before attaching an air hose or accessory, make sure the shut-off valve is in the closed position. Make sure the ON/AUTO lever is in the OFF position.



Compressed air from the unit may contain water condensation and oil mist. Do not spray unfiltered air at an item that could be damaged by moisture. Some air tools may require filtered air. Read instructions for air tool or device.

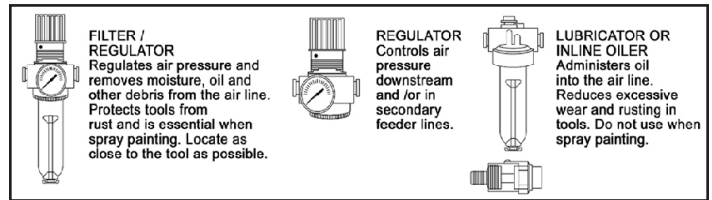

3. Attach regulator, hose and accessory. An air pressure regulator, must be installed before using accessories rated at less than 175 psi.



Too much air pressure causes a hazardous risk of bursting. Check the manufacturer's maximum pressure rating for air tools and accessories. The regulator outlet pressure must never exceed the maximum pressure rating for the tool or accessory.

4. Place the pressure switch lever in the ON-AUTO position. The motor will stop when air tank pressure reaches "cut-out pressure".

5. Open the shut-off valve.

6. If an air pressure regulator is in use, open the regulator by turning it clockwise. Adjust the regulator to the correct pressure setting. Your unit is ready for use.

When You Are Finished:

7. Turn the air compressor unit off.

8. Turn the regulator counterclockwise and set the outlet pressure to zero, then remove the air tool or accessory.

9. Open the regulator and allow the air to slowly bleed from the air tank. Close the regulator when air tank pressure is approximately 20 psi.

10. Open the drain valve underneath the air tank and drain water from air tank. If the air compressor is under continuous use, drain at least once each day. If the air compressor is only used occasionally, drain after each use.

11. After water has been drained, close the drain valve.

⚠ WARNING

DRAIN AIR TANK DAILY. Water will condense in the air tank. If not drained, the water will corrode and weaken the air tank, causing a risk of air tank rupture. The air tank must be drained properly. If the air compressor is under continuous use, drain at least once each day. If the air compressor is only used occasionally, drain after each use.

⚠ WARNING

If the tank drain valve is clogged, first release the air pressure in the air tank. The tank drain valve can then be removed, cleaned and reinstalled.

MAINTENANCE



⚠ DANGER
 SERVICING WHILE PRESSURIZED CAN CAUSE SEVERE INJURY.
 LOCK OUT SOURCE AND RELIEVE PRESSURE BEFORE SERVICING.

Disconnect, tag and lock out power source then release all pressure from the system before attempting to install, service, relocate or perform any maintenance.

TANK

Drain liquid from tank daily or after each use. The tank should be carefully inspected at a minimum of once a year. Look for cracks forming near the welds.

⚠ DANGER

Never attempt to repair or modify a tank! Welding, drilling or any other modification will weaken the tank resulting in damage from rupture or explosion. Always replace worn, cracked or damaged tanks. If a crack is detected, remove pressure from tank immediately and replace.

COMPRESSOR LUBRICATION

Add oil as required. The oil and should be changed every three months or after every 300 hours of operation; or whichever comes first.

If the compressor is run under humid conditions for short periods of time, the humidity will condense in the crankcase and cause the oil to look creamy. Oil contaminated by condensed water will not provide adequate lubrication and must be changed immediately. Using contaminated oil will damage bearings, pistons, cylinders and rings and is not covered under warranty. To avoid water condensation in the oil, periodically run the compressor with tank pressure near 150 psi by opening the tank drain or an air valve connected to the tank or hose. Run the pump for an hour at a time at least once a week or more often if the condensation reoccurs.

The following table is a list of routine maintenance items, including service intervals. Service intervals are listed as hours, days or weeks, whichever occurs first.

Service Intervals				
Maintenance operation	Daily	Weekly	Monthly	Hourly
Drain air tanks	☑	☑	☑	☑
Check crankcase oil level	☑			
Check fittings and airlines	☑			
Inspect belt and tension	☑			
Inspect and clean air intake filters		☑		
Inspect check valve		☑		
Replace air filters			6	
Inspect and clean compressor valves			6	
Tighten all fittings and fasteners			3	
Check all electrical connections			3	
Check compressor reed valves				250
Drain and replace crankcase oil			3	500

Under normal operating conditions, oil changes are required every 3 months. When operating in a dirty environment, change the oil more frequently as your particular operating condition dictates.

AIR FILTER

Never run the compressor pump without an intake air filter or with a clogged intake air filter(s). Use compressed air to blow the filters clean. Do not wash or oil the element. If it cannot be blown clean, the filter(s) must be replaced.



Operating compressor with a dirty filter can cause high oil consumption and increase oil contamination in the discharge air.

INTERCOOLER TUBING



Intercooler fins are very sharp. Always wear gloves and use care when you clean or work near the intercooler tubing. Weekly, check the intercooler to be sure all fittings are secure and tight. Blow all dirt, dust and other accumulations from the intercooler fins.

COMPONENTS

Turn off all power and use light air pressure to blow dust and foreign material from cylinder head, motor, fan blades, air lines, intercooler and tank on a monthly basis.



When using an air blow gun always wear eye protection and face mask/respirator. Fast moving air will stir up dust and debris which may be harmful.



BELTS

The v-belt(s) should be adjusted so that a declination of about 3/8 – 1/2 inch will be obtained when it is pushed by a finger at the middle point as shown.

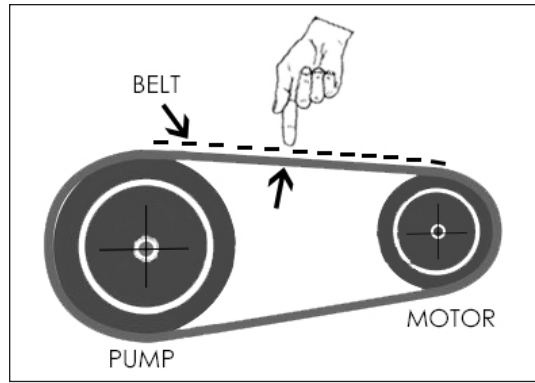

Over tightening the v-belt(s) will result in overloading of the motor and belt failure, while a loose belt will be slipping and resulting in an unstable speed, vibration, overheating the belt and high amp draw. To change tension, loosen the motor hold-down bolts and slide the motor on the base, using a lever if necessary, or by turning the adjusting bolt at the end of the base. Retighten motor hold-down bolts.

NOTE: DO NOT OVER TIGHTEN BELTS.

Also, align belts using a straight edge against the face of the flywheel and touching the rim on both sides of the face. The belts should be parallel to this straight edge. Dimension A should be the same as B and C to ensure proper alignment of the belts. Slots in the bed-plate allow for sliding the motor back and forth to adjust belt tension.

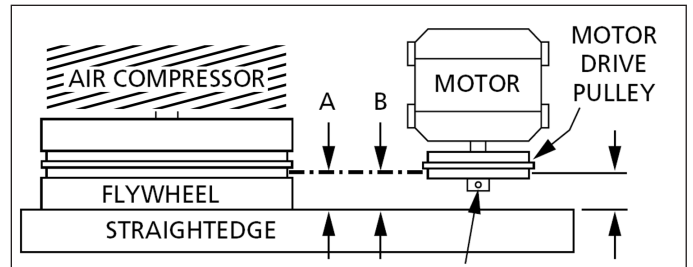

TROUBLESHOOTING

Problem	Possible Cause	Solution
Compressor runs hot	<ul style="list-style-type: none"> Check compressor rotation Compressor reed valves Dirty intake filter Low oil Level Check valve leaking 	<ul style="list-style-type: none"> Check fittings on hydraulic motor Inspect, clean or replace valves Clean filter assembly Level Add oil if needed Disassemble, clean, and re-install
Compressor does not run	<ul style="list-style-type: none"> No Power to Compressor Air reservoir full Hydraulic lines not connected Couplers or hoses blocked Air load against compressor Hydraulic pump not working Hydraulic motor not working Check valve leaking 	<ul style="list-style-type: none"> Check Fuse Drain and activate pressure switch Connect lines Locate and remove restriction Relieve air pressure Check flow and pressure settings Inspect and repair Disassemble, clean, and reinstall or replace

Problem	Possible Cause	Solution
Compressor runs too slow	Compressor reed valves Check for hose leaks Hydraulic flow too low Hydraulic motor worn Power unit relief set too low Hydraulic system too hot Speed control not working	Inspect, clean or replace valves Tighten any hose fitting leaking Check and reset flow Replace with new motor Readjust relief valve Reservoir too small. Add cooler to system. Check power supply and readjust
Compressor will not stop	Air pressure switch set wrong Leaking hoses or fittings	Check points and setting on switch Tighten all fittings and hoses
Air output too low (air pressure okay)	Low compressor speed Air filter dirty Airlines leaking Check valve plugged	Refer to compressor too slow Clean or Replace Filters Retighten hoses Remove and clean check valve
Compressor cycles (air not being used)	Leaks in air line Air pressure switch set wrong Dirt in solenoid valve	Tighten hoses and fittings Check cut-in and cutout settings Remove and clean
Air Output low (Air Pressure Low)	Dirty air filter Intake reed valves malfunction Insufficient torque on head bolts	Inspect and clean filter If air back-flows from air filter, reed valve needs to be replaced. Tighten bolts to required torque
Air pressure too low	Air pressure switch set wrong Air line leak Air consumption exceeds Compressor capacity Intake or exhaust valves damaged	Readjust high pressure setting Inspect and tighten loose hoses Check air demand for items using air supply Inspect and replace
Air pressure too high	Pressure switch not operating Internal contamination Pressure switch not adjusted	Inspect and clean Inspect and clean Readjust to lower pressure
High crankcase oil usage	Oil level too high Oil leaks Piston rings worn or broken	Check oil level and drain if needed Inspect and repair gaskets or seals Replace rings
Blowing oil from crankcase breather	Blown head gasket Piston rings worn or broken Oil level in crankcase too high Hole in piston	Replace gasket Replace rings Check oil level and drain Replace piston
No lubricating oil pressure	Air lock in oil pump No oil in crankcase Pump suction blocked	Check oil level and add Remove oil intake plug and inspect intake and screen. Clean blockage.

TS-580V-601 PARTS LIST

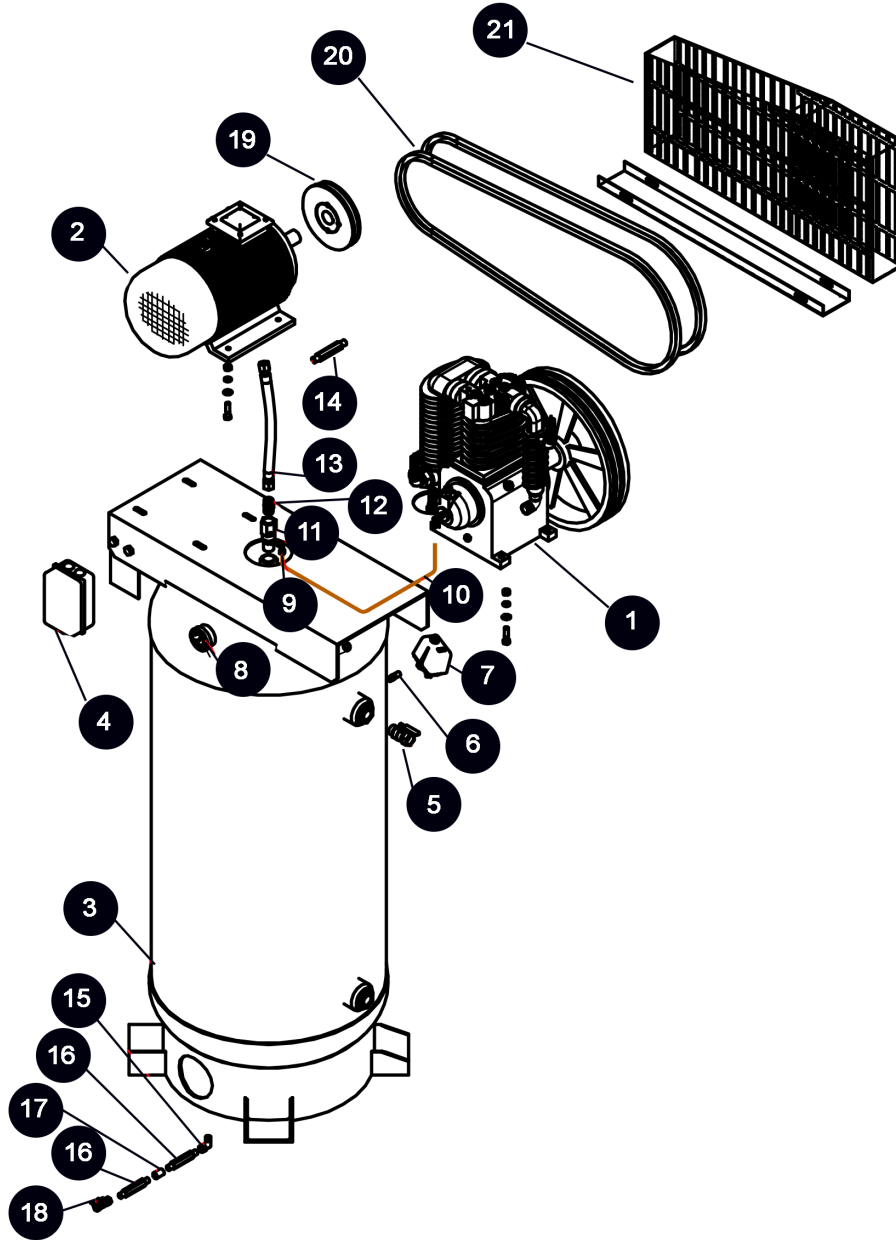

No.	DESCRIPTION	QTY.
1	PUMP	1
2	MOTOR	1
3	AIR RECEIVER	1
4	MAGNETIC SWITCH	1
5	BALL VALVE	1
6	NIPPLE	1
7	PRESSURE SWITCH	1
8	PRESSURE GAUGE	1
9	UNLOADING ELBOW	1
10	UNLOADING COPPER PIPE	1
11	CHECK VALVE	1

No.	DESCRIPTION	QTY.
12	FLARED JOINT	1
13	EXHAUST PIPE	1
14	AIR RECEIVER	1
15	ELBOW	1
16	NIPPLE-M	2
17	NIPPLE-F	1
18	BALL VALVE	1
19	TAPER-LOCK PULLEY	1
20	V-BELT	1
21	BELT GUARD	1

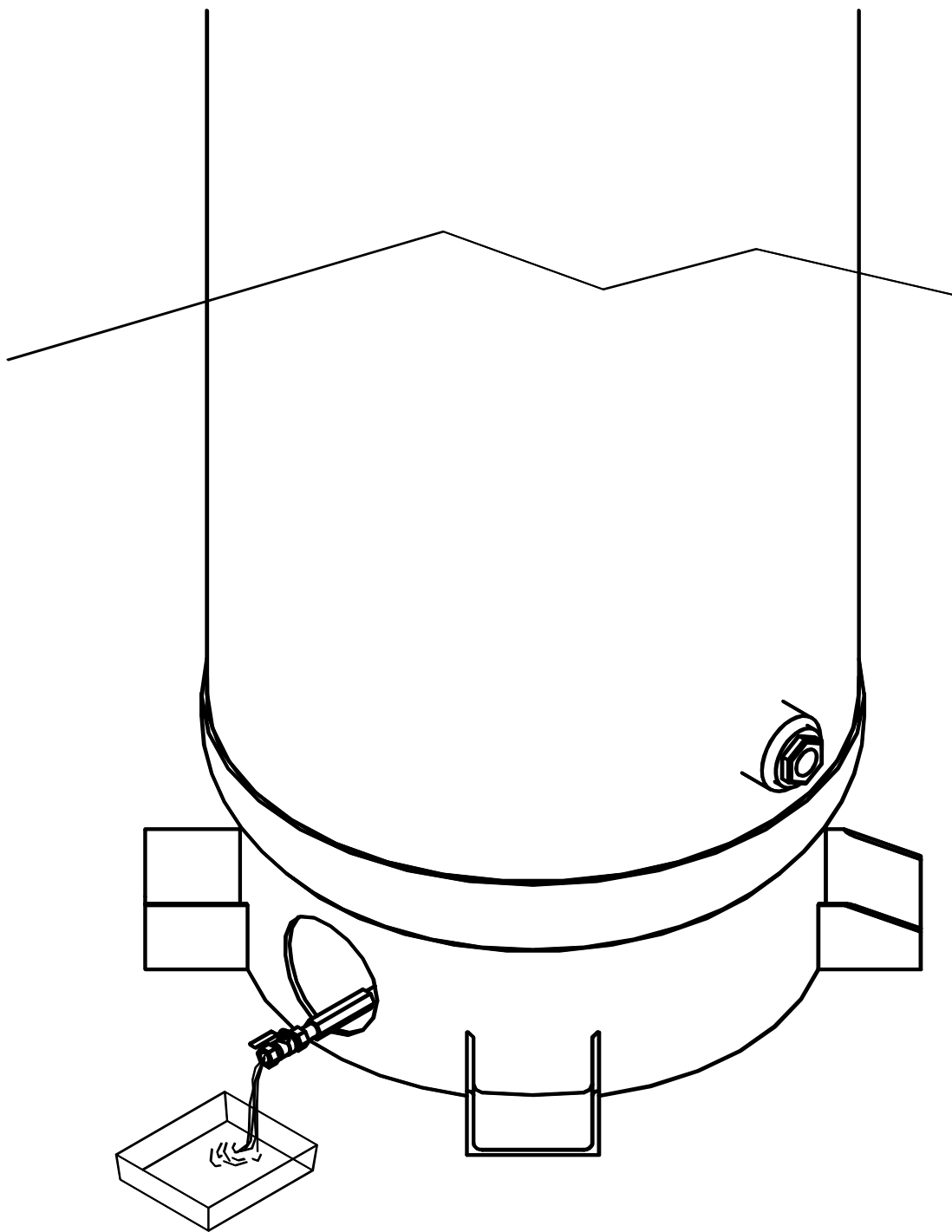

WATER DRAINAGE

⚠ WARNING

OUR UNITS ARE SHIPPED WITH NO OIL. FILL WITH OIL BEFORE STARTING. CHECK THE OIL LEVEL AND QUALITY BEFORE OPERATING THE COMPRESSOR. DO NOT ADD OR CHANGE OIL WHILE COMPRESSOR IS IN OPERATION. USE ONLY THE BELOW RECOMMENDED COMPRESSOR OIL:

ISO100, NON-DETERGENT, COMPRESSOR OIL.

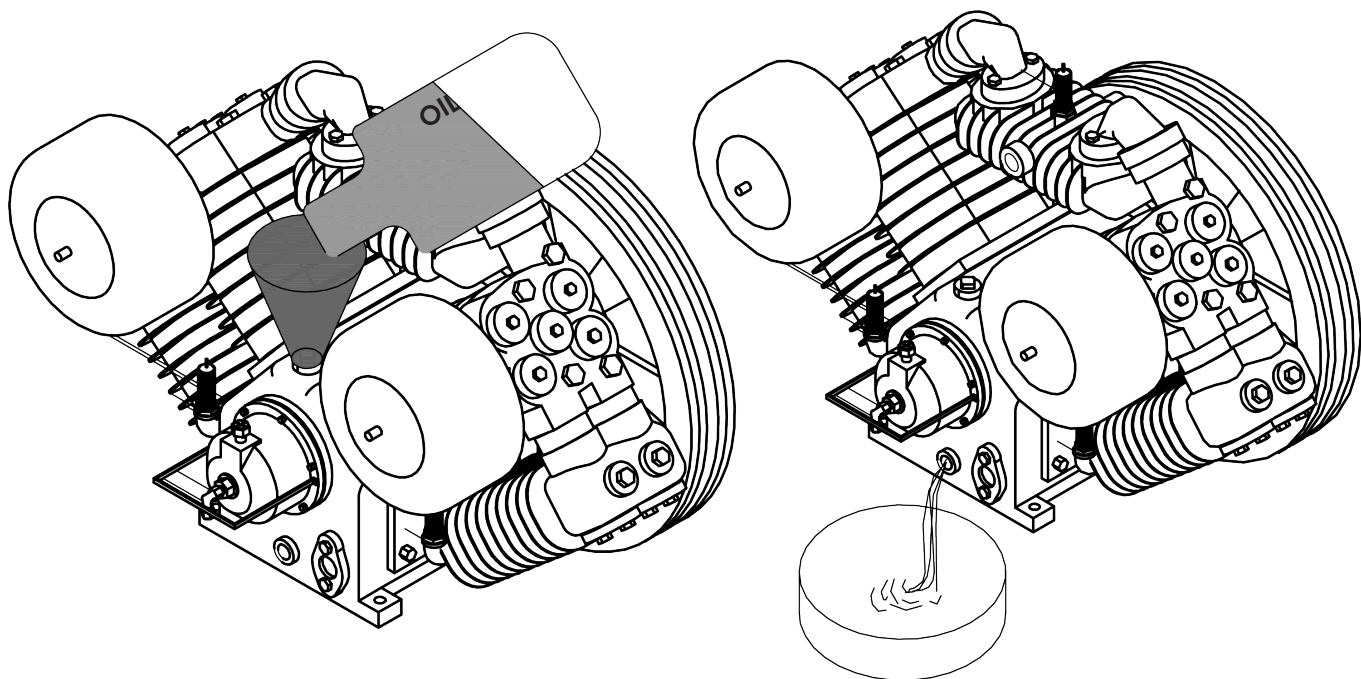

CHANGING OIL

SPECIFICATIONS



MODEL:	TS-580V-601
Tank:	300 L / 80 Gal / Vertical
Voltage (*)	208-230VAC
Running HP	5
Phase	1
Hertz	60
Running Load Amps (SFA)	26-23.8A
Peak Start-up Amps	54-48A
Recommended Breaker	30A
Motor Duty Cycle	Continuous
Pump Style	2-Stage/2-Piston/Vertical
Shut-off Pressure	175 PSI
Turn-on Pressure	145 PSI
Pump Material	100% Cast Iron
Pump RPM	625
Motor RPM	1740
Lubrication	Splash / Oil
CFM @ 90 PSI	17.9
CFM @ MAX PSI	17.2
MAX PSI	175 PSI
Noise Level	75 db
Certification	ASME
Dimensions (W x D x H)	39"x26"x79" / 991x660x2006
Product Weight	619 lb / 281 kg
Limited Warranty (Months)	Tank-60/Pump-24/Other-12



TS-5 Elite™ & V-MAX Elite™ AIR COMPRESSORS WARRANTY

Better Products – Better Service – Better Value

Duration: From date of purchase by the original Purchaser or 60-24-12 months from the date of shipment by BendPak or whichever comes first.

- ✓ **Five Years (60-Months) Warranty** on the compressor tank only
- ✓ **Two Years (24-Months) Warranty** on the compressor pump only
- ✓ **One Year (12-Months) Warranty** on operating components
- ✓ **One Year (12-Months) Labor Warranty** on site or at factory
- ✓ **One Year (12-Months) Free-Shipping*** on ground-freight charges related to warranty performance

Limited Warranty

9. Who gives this warranty (Warrantor): BendPak Inc., 1645 Lemonwood Dr., Santa Paula, CA 93060
10. Who receives this warranty (Purchaser): The original Purchaser (other than for purpose of resale)
11. What products are covered by this warranty: Any BendPak Tri-Max Air Compressor**
12. What is covered under this warranty: manufacturer defects due to material and/or workmanship with the exceptions noted below.
13. What is not covered under this warranty:
 - a. Any failure that results from Purchaser's abuse, neglect or failure to operate, maintain or service product in accordance with instructions provided in the owner's manual(s) supplied or any pre-delivery service, (assembly, oil, lubricants, adjustment etc.)
 - b. Items or service normally required to maintain the product, i.e. lubricants, oil, etc.
 - c. Items considered general wear parts such as rubber belts, hoses, etc. unless wear or failure is a direct result of manufacturer defect due to material and/or workmanship Other items not listed but considered general wear parts; a. Pump wear or valve damage caused by using oil not specified; b. Pump or valve damage caused by any oil contamination or by failure to follow proper oil maintenance guidelines; c. Ring wear or valve damage from inadequate filter maintenance
 - d. Any component damaged in shipment or any failure caused by installing or operating air compressor under conditions not in accordance with installation and operation guidelines or damaged by contact with tools or surroundings
 - e. Motor or pump failure caused by rain, excessive humidity, corrosive environments or other contaminants
 - f. Rusted tanks, including but not limited to rust due to improper drainage or corrosive environments. The five-year tank warranty applies to ASME air receivers only if they are installed on rubber anti-vibration pads or approved equivalent.
 - g. Cosmetic defects that do not interfere with product functionality
 - h. Damage due to incorrect voltage or improper wiring
 - i. Any incidental, indirect, or consequential loss, damage, or expense that may result from any defect, failure, or malfunction of BendPak Inc. product
 - j. All electrical components are guaranteed for one year against defects in workmanship and/or materials when the lift is installed and used according to specifications.
14. Responsibilities of Warrantor under this warranty: Repair or replace, at Warrantor's option, component which is defective, has malfunctioned and/or failed to conform within duration of the warranty period. BendPak Inc. will pay reasonable labor costs for the first 12 months only
15. Responsibilities of Purchaser under this warranty:
 - a. Provide dated proof of purchase and maintenance records
 - b. In some cases, components may be required to be shipped to the nearest BendPak Authorized Service Center. Freight costs, after 12-months, must be borne by the Purchaser.
 - c. Use reasonable care in the operation and maintenance of the products as described in the owner's manual(s).
16. When Warrantor will perform repair or replacement under this warranty: Repair or replacement will be scheduled and serviced according to the normal work flow at the servicing location, and depending on the availability of replacement parts.

*Free-shipping applies to direct shipping points within the 48 continental United States. Rural area shipping surcharge may apply for remote addresses. **For all BendPak brand Two-Post or Four-Post Vehicle Service Lifts (excluding specialty lifts, high rise, commercial parking, material handling, or models for particular purpose) manufactured on or following 1/1/2011.

Limitation of Liability

BendPak/Ranger shall have no obligation pursuant to this Warranty with respect to products which in our sole judgment have been altered, damaged, misused, abused, badly worn, lost or improperly maintained. This Warranty is null and void if the customer or any other person other than an authorized representative of BendPak/Ranger has made any attempt to service or modify the tool prior to its return to BendPak/Ranger under this Warranty. In no event will either party be liable for any damage caused by the other party's failure to fulfill its responsibilities under these terms and conditions. In no event will either party be liable for any lost profits, lost savings, incidental damage, or other economic consequential damages. BendPak/Ranger products are provided and sold as is without any express or implied warranties including warranties of merchantability or fitness for particular purpose. No warranties, expressed or implied, will apply after this period. BendPak may modify these terms and conditions at any time by either providing the customer with written notice or posting such revised terms on www.bendpak.com. Such revised terms shall be effective thirty days from the date of such written notice or posting.



1645 Lemonwood Dr. ● Santa Paula, CA. 93060, USA
Toll Free: 1(800) 253-2363

FOR TECHNICAL SUPPORT
1-(800) 253-2363 Ext. 196
TO ORDER PARTS
1-(800) 253-2363 Ext. 191